



bezoekadres
Poppenbouwing 56
4191 NZ Geldermalsen

postadres
Postbus 202
4190 CE Geldermalsen

T +31 (0)88 244 01 00
F +31 (0)88 244 01 01
E info@skgikob.nl
I www.skgikob.nl

**SKG-IKOB – Test methods for locks
(for mobile objects)
(TMS-05)**

**TO BE PERFORMED ON BEHALF OF HOMOLOGATION
DIRECTIVES FOR MECHANICAL SECURITY OF MOBILE
OBJECTS**

Compiled by i.a. the Certifying institute Stichting ART

***These TMS guidelines are a translation of the original Dutch text.
Should there be disputes with regard to interpretation, the Dutch text
shall be binding.***

INTRODUCTION

This TMS-05 document is a revised version of the d.d. 1-1-2025 document.

This guideline has been prepared by various domestic and foreign experts parties and in near collaboration with i.a. the Technical Commission (TC) of Stichting ART and the Board of Experts for Mechanical Security Systems for Vehicles and (parts of) vessels (CvD) of The Centre for Crime Prevention and Safety (CCV), which interested parties in their directives are represented.

These above mentioned parties, in which e.g. end users, manufacturers, insurers, testing authorities, certification bodies and the Dutch Police work together, can also propose and/or discuss changes to this guideline if necessary.

This guideline will be used by SKG-IKOB in conjunction with i.a. the regulations applied by Stichting ART or CCV.

This test method document may be used for other standards as well if announced to and agreed by SKG-IKOB.

In this guideline, test methods of tests are described which could be necessary to set the execution of the research to obtain a product certificate.

© 2026 SKG-IKOB

Binding declaration

This guideline is declared binding on June 2026 by the Board of directors of Stichting ART.



SKG-IKOB
Poppenbouwing 56
4191 NZ Geldermalsen
Postbus 202
4190 CE Geldermalsen
The Netherlands
Telephone +31 (0)88-2440100
Internet www.skgikob.nl



Summary

This document contains the description of how to execute the tests on mechanical (and mechatronic) security-systems for mobile objects, like locks for two-wheelers, wall-, floor-, or ground-anchors, wheel-clamps or (hitch) locks for caravans and trailers, steer locks for cars, HGV or container locks, locks for outboard motors etc.

There are different domestic and foreign homologation directives for these security-systems like the Dutch ART Homologation Directive for Mechanical Security Systems for Two-wheeled vehicles (MBT series) and the Dutch CCV Inspection Regulations Mechanical Security (MB/MS series).

These homologation directives specify performance requirements and describe which tests the various products have to pass. More detailed test descriptions can be found in this document.

The homologation directives are being issued by the Certifying institute or the scheme manager as mentioned above in close collaboration with SKG-IKOB Certification.

Changes in these homologation directives can have consequences for the use of (parts of) this document.

TABLE OF CONTENTS	PAGE
1. INTRODUCTION.....	6
1.1 Subject-matter	6
1.2 Scope	6
1.3 Date of commencement and period of validity	6
1.4 References / Basic Regulations	6
2 Specific test methods.....	7
2.1 Durability tests (on locks and lock parts)	7
2.1.1 Usage resistance (frame) locks (open and close)	7
2.1.1.1 Test conditions	7
2.1.1.2 Test procedure	7
2.1.2 Resistance of electronically operated frame locks to vibrations	8
2.1.2.1 Test conditions	8
2.1.2.2 Test procedure	8
2.1.3 Mechanical resistance of locks or lock parts to free falls (drop impact test)	9
2.1.3.1 Test conditions	9
2.1.3.2 Test procedure	9
2.1.4 Resistance to key removal in unlocked position (for Frame locks)	10
2.1.4.1 Test procedure	10
2.1.4.2 Test procedure	10
2.2 Weather (environmental) resistance tests	11
2.2.1 Corrosion resistance	11
2.2.1.1 Test conditions	11
2.2.1.2 Test procedure	11
2.2.2 Dust resistance	12
2.2.2.1 Test conditions	12
2.2.2.2 Test procedure	12
2.2.3 Freeze resistance / Cold test (mechanical locks)	13
2.2.3.1 Test conditions	13
2.2.3.2 Test procedure	13
2.2.4 Freeze resistance / Cold test (electronically operated locks)	14
2.2.4.1 Test conditions	14
2.2.4.2 Test procedure	14
2.3 Mechanical strength tests (machine tests)	15
2.3.1 Torsional (torque) strength	15
2.3.1.1 Test conditions	15
2.3.1.2 Test procedure	15
2.3.2 Tensile strength	16
2.3.2.1 Tensile strength test 1a (in direction of opening - U-shackle lock)	16
2.3.2.2 Tensile strength test 1b (Fully flexible (e.g. cable) locks).	17
2.3.2.3 Tensile strength test 1c (Hard link (e.g. chain and folding) locks).	18
2.3.2.4 Tensile strength test 2 (perpendicular to the direction of opening - U-shackle lock)	19
2.3.2.5 Tensile strength test 3 (anchor systems e.g. Wall- and Floor-anchors)	20
2.3.2.6 Tensile strength test 4a (simulated cylinder pull test (pushing from the opposite side))	21
2.3.2.7 Tensile strength test 4b (actual plug/cylinder extraction test with a pulling screw))	22
2.3.2.8 Tensile strength test 5 (pull out the additional mean – Plug-in mechanism)	23
2.3.3 Cutting strength (resistance to shearing)	23
2.3.3.1 Test conditions	24
2.3.3.2 Test procedure	24
2.3.4 Powerkey torque strength (resistance to a Power-Key attack test cycle (2.0 version 2024)).	25
2.3.4.1 Test conditions	25
2.3.4.2 Test procedure	25

2.4	Mechanical strength tests (manual attack tests)	26
2.4.1	Attacking tests (resistance to lock picking)	26
2.4.1.1	Attacking test type 1 (manipulation/picking, non destructive unlocking test with hand tools)	26
2.4.1.2	Test conditions	26
2.4.1.3	Test procedure	26
2.4.2	Attacking tests (resistance to brute attacks)	26
2.4.2.1	Attacking test type 2 (brute attack, destructive unlocking test with various hand tools)	27
2.4.2.2	Test conditions	27
2.4.2.3	Test procedure	27
2.5	Functional tests	28
2.5.1	5 meters function test E-locks (open field function test mechatronic locks with remotes)	28
2.5.1.1	Test conditions	28
2.5.1.2	Test procedure	28
2.6	Various tests	29

1. INTRODUCTION

1.1 Subject-matter

This guideline contains the description of how to execute the tests on mechanical (and mechatronic) security-systems for mobile objects. In the homologation directives for these security-systems, like the ART MBT Homologation Directive and the CCV MB/MS Inspection Regulations series, both the performance requirements and which tests the various products have to go through are described in detail.

1.2 Scope

Products in accordance with the regulations applied by Stichting ART, CCV or Kiwa SCM, contribute to social safety concerning burglary resistance or theft-prevention of mobile objects such as:

- locks for two-wheelers (bike, scooters, motorcycles),
- anchorage elements (floor- and wall-anchors),
- wheel-clamps for caravans and trailers,
- hitch locks for caravans, trailers and semi-trailers,
- steerlocks for cars, vans, campers and HGV,
- gearbox locks for cars, vans, campers, delivery vehicles and HGV,
- loading door locks cars, vans, delivery vehicles and HGV,
- locks for containers,
- locks for outboard motors on pleasure craft and small boats,
- etc..

1.3 Date of commencement and period of validity

These SKG-IKOB-TMS will take effect immediately on the date of publication.

These SKG-IKOB-TMS may be cited as:

TMS-05: Test methods for locks.

1.4 References / Basic Regulations

Products in accordance with the regulations applied by the Foundation ART and CCV (SCM).

- MBT-04 Mechanical security systems for two-wheeled vehicles.
- CCV Ir-MS series CCV Inspection Regulations Mechanical Security.
- EN 15496 Cycles – Requirements and test methods for cycle locks.
- EN 12320 Building hardware - Padlocks and padlock fittings - Requirements and test methods.
- VF 5029 series Bicycle Locks - Requirements.
- SSF 011 series Bicycle locks - Requirements and testing.
- TFFN 701/702 series Locks for mopeds and motorcycles- Requirements and methods.
- EN 1670 Building hardware - Corrosion resistance - Requirements and test methods.
- ISO 9227 Corrosion test in artificial atmospheres - Salt spray tests.
- ISO 4628-3 Paint and varnishes- Evaluation of degradations of coatings (Part-3: Assessments of degree of rusting)
- EN-IEC 60529 Degrees of protection provided by enclosures (IP Code)

2 Specific test methods

2.1 Durability tests (on locks and lock parts)

2.1.1 Usage resistance (frame) locks (open and close)

The lock must have a durability such that it will still function properly (no loss of function) after being subjected to a number of cycles mentioned in the relevant directive.

2.1.1.1 Test conditions

Temperature	23 °C ± 5 °C
Humidity	35 – 95%

The test has to be carried out on a new lock.

Before each individual test, the function of the lock must be checked (lock and unlock the unit, withdraw and insert the key after locking).

The (frame) lock shall be opened and closed for the required number of cycles specified in the homologation directive (specifications, regulations, etc.) at a rate of no more than 20 cycles per minute.

2.1.1.2 Test procedure

The lock is placed and mounted on the durability test equipment (see images below) after which the lock mechanism is activated for the number of cycles mentioned in the directive.

The time needed to carry out one (1) cycle is at least 3 seconds.

A cycle is defined as the time needed to engage and disengage the lock.

An example of a cycle is given below.

For locks for which the described lock testing apparatus cannot be used, an equivalent test method should be used.

One cycle of the (ring-lock) test procedure shall consist of the following steps:

Step 1: Turn the key from rest to the unlocking position.	Time: ≥ 0,5 seconds,
Step 2: Move the locking shackle to a closed position (e.g. with a closing device).	Time: ≥ 0,5 seconds,
Step 3: Turn the key back to the rest position.	Time: ≥ 0,5 seconds,
Step 4: Move the apparatus closing device back to the starting position.	Time: ≥ 0,5 seconds,
Step 5: Turn the key to unlocking position (the shackle moved to open position).	Time: ≥ 0,5 seconds,
Step 6: Turn the key back to the rest position.	Time: ≥ 0,5 seconds,

During and after the test the lock shall retain its normal function (locking and unlocking).

Based on locking and unlocking the lock, as well as inspection of the lock, it is decided whether the requirements are fulfilled or not.

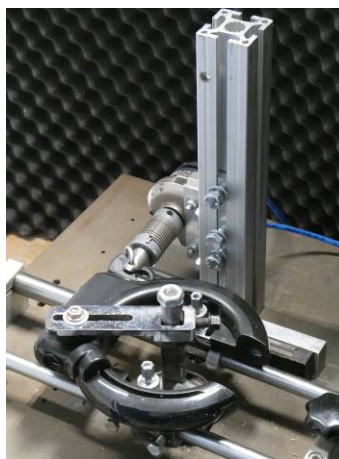
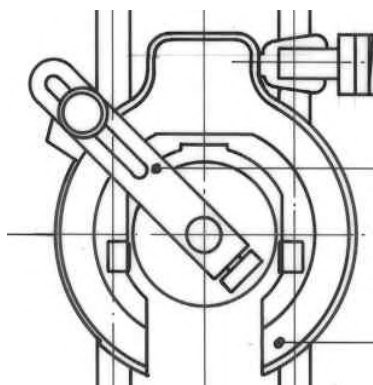

2.1.2 Resistance of electronically operated frame locks to vibrations

The lock must have a durability such that it will still function properly (no loss of function) after being subjected to a number of cycles mentioned in the relevant directive.

2.1.2.1 Test conditions

Temperature	23 °C ± 5 °C
Humidity	35 – 95%

The test has to be carried out on a new lock.

Before each individual test, the function of the lock must be checked (lock and unlock the unit).

The electronically operated (frame) lock shall be tested according to the vertical test method for rear bicycle luggage carriers (such as mentioned in EN 14872 or ISO 11243) with the following parameters:

Frequency of 7 Hz (+0, -2 Hz), vertical sinusoidal strokes of 10 mm (+2 mm, -0 mm) and 100.000 cycles.

Optional another required number of cycles could be specified in the relevant homologation directive.

2.1.2.2 Test procedure

The lock is placed and mounted on the durability test equipment (installed in the fixture, see for example the images below) after which the machine continues (runs) the number of cycles mentioned in the directive.

After the test the lock shall retain its normal function (locking and unlocking).

Based on locking and unlocking the lock, as well as inspection of the lock, it is decided whether the requirements are fulfilled or not.

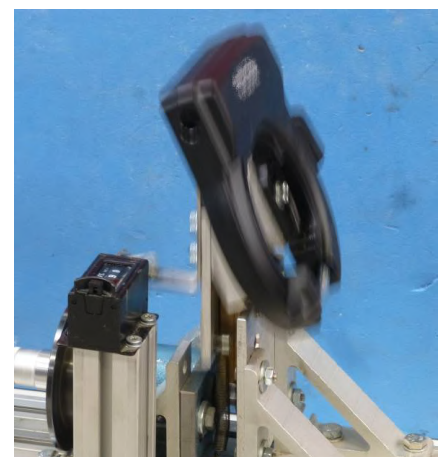
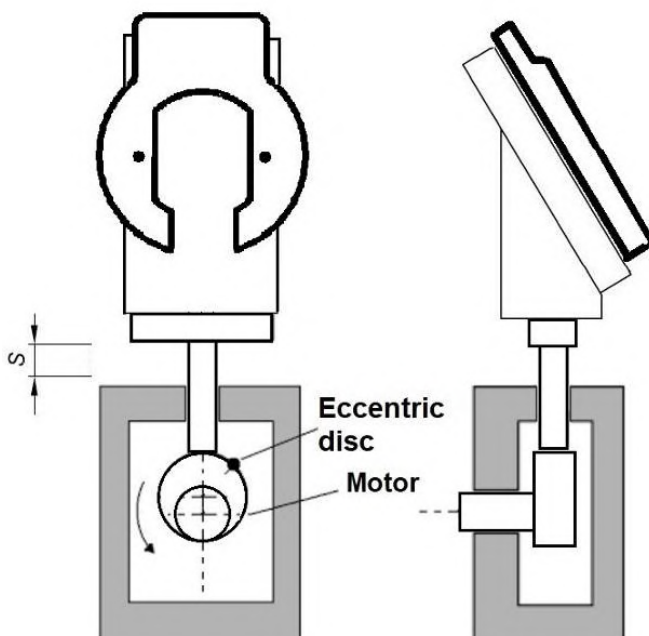

2.1.3 Mechanical resistance of locks or lock parts to free falls (drop impact test)

The non-permanently fixed lock or a loose part of the lock (including electronic keys) must have a durability such that it will still function properly after being subjected to a number of (gravitational force) drops from a certain height as mentioned in the relevant directive.

2.1.3.1 Test conditions

Temperature	23 °C ± 5 °C
Humidity	35 – 95%

The test has to be carried out on a new or undamaged lock, mechatronic lock (E-lock) or electronic key. Before the test, the functioning of the lock must be checked (lock and unlock the unit). If applicable (mentioned in the relevant directive) the lock shall be conditioned before the drop test. The object (lock, lock-part, electronic key, etc.) shall be dropped with the following (ART, CCV) parameters: 5 free falls (complete product), 50 free falls (lock parts, electronic keys, remote, etc.), height 100 cm (± 10 cm), hard surface (e.g. a concrete floor or a massive concrete tile).
Remark: The number of drops or drop height can vary in other (non ART, CCV) homologation directives.

2.1.3.2 Test procedure

The drop impact test is performed under normal laboratory conditions. After removed from conditioning (if applicable) the lock, lock part or remote shall be released within 60 seconds from a required height. The lock is moved in a position perpendicular above a hard surface (e.g. a concrete floor). The position angle (upright or tilted position) of the lock or lock part (e.g. electronic key) during the drop impact test will be such that it will fall in different ways (e.g.: worst position and various tangent planes with the floor). This is to be determined by the testing authority (test house). The test object is held (firmly) in position before the actual free fall by hand or other (with the help of supports if needed). The height is as specified in the relevant homologation directive measured from the lowest part of the object (held next to a reference height test-rig, see images below). The test object (lock or key) is subjected to the number of drops mentioned in the directive. If the object breaks apart during the test in such manner that it can be reassembled, this will be done (with or without an in between function test), and the testing will continue until the number of drops have been completed. The lock may get damaged. If the object breaks and cannot be reassembled (provisory and working), it is registered as the lock failing the test. After the test it must be possible to open the lock. Therefore the lock itself and/or an electronic key must be functioning (unlocking and locking). Based on the function tests, as well as inspection of the lock (parts), it is decided whether the requirements are fulfilled or not.

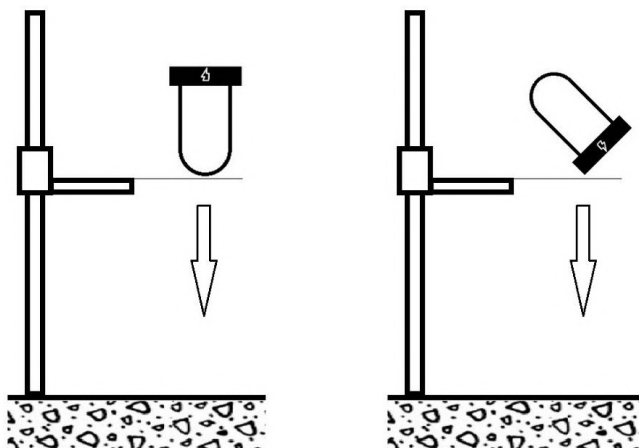

2.1.4 Resistance to key removal in unlocked position (for Frame locks)

The key of an unlocked frame lock must remain in the key barrel when a certain torque and pulling force is exerted. The forces used are mentioned in the relevant directive.

2.1.4.1 Test conditions

Temperature	23 °C ± 5 °C
Humidity	35 – 95%
Time tolerance	±1 s.

The test has to be carried out on a new lock.

Before the test, the function of the lock must be checked (lock and unlock the unit, withdraw and insert the key after locking).

The frame lock should be mounted in a test rig so that it appears as if the frame lock is permanently mounted to a vehicle. The frame lock must be mounted securely so that it does not move while the torque and pulling force is applied to the key.

2.1.4.2 Test procedure

The frame lock is securely mounted to a test rig so that it cannot move when torque and pulling force is applied to the key. The position of the lock during the test will be representative of “normal use”.

If unknown, the worst situation will be used (e.g. upright, lying flat, other).

This is to be determined by the testing authority (test house).

The key is subjected to both a torque- and a pulling force at the same time, as if someone were trying to pull the key out of the lock with brute force. The torque applied to the key is turned in the open direction. Make sure that the pulling force is perpendicular to the centre of the key blade.

Both forces of the torque and pulling will be reached within 2 seconds.

The forces are held for a maximum of 5 seconds.

After 5 seconds, both forces are released to the key's rest position.

Based on the behaviour during the test, as well as inspection of the lock (part) after the tests, it is decided whether the requirements are fulfilled.

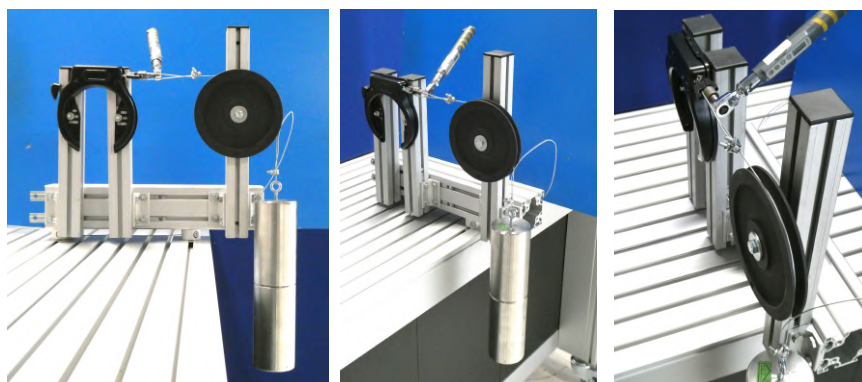
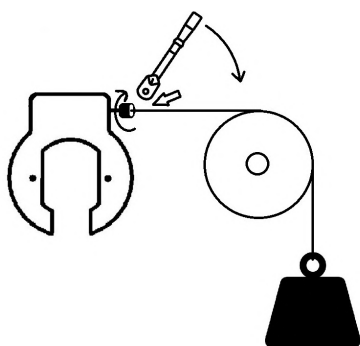

2.2 Weather (environmental) resistance tests

2.2.1 Corrosion resistance

The lock must withstand exposure to corrosion for a number of hours (mentioned in the relevant directive) such that it will still function properly (without loss of function) after being rinsed off and dried.

2.2.1.1 Test conditions

Temperature	23 °C ± 5 °C
Humidity	35 – 95%

The test has to be carried out on a new lock.

Before the test, the function of the lock must be checked (lock and unlock the unit, withdraw and insert the key after locking).

The corrosion test will be performed using the European Standard EN 1670, paragraph 5.6 as a guide.

The lock is placed in a salt fog chamber for the number of hours mentioned in the relevant directive.

2.2.1.2 Test procedure

The lock is placed in a salt fog chamber (installed in the fixture, see images below).

The position of the lock during the corrosion test will be simulating the way of “normal use”.

If unknown, the worst situation will be taken (e.g. upright, lying flat, other).

This is to be determined by the testing authority (test house).

After the corrosion test cycle is performed (the number of hours is mentioned in the directive) the lock will be gently rinsed with clean water (temperature ≤ 38 °C) to remove any salt deposit that may have formed and then allowed to dry at room temperature for 24 hours before the final inspection.

After the test, the lock must not have lost its functions (capable of functioning normally).

Remark: the lock must be able to be opened with a reasonable maximum torque on the key (e.g. 2,5 Nm max).

If a maximum torque value is applicable then this is mentioned in the relevant directive.

Therefore it is permitted to make the product functional for 2 minutes with manual force and using only the correct key.

After the salt fog chamber test it must not be so rusty that the lock function is affected negatively or that the lock can be activated by accident.

Additionally for visual reasons (goal: Appearance: not badly corroded) the degree of rust of metal parts can be determined using a rust indication (Ri) scale from Ri = 0 (no rust) till Ri = 5 (severe rust).

For this the standard ISO 4628-3 can be used as a guide (for coated surfaces) or an equivalent standard for determined the rust (rust resistance).

Based on locking and unlocking the lock, as well on an inspection of the lock it is decided whether the requirements are fulfilled or not.



2.2.2 Dust resistance

The lock must withstand exposure to dust for a number of hours (mentioned in the relevant directive). Ingress of dust is not entirely prevented, but it must not enter in sufficient quantity to interfere with the satisfactory operation of the lock (such that it still functions properly (without loss of function) after the test).

2.2.2.1 Test conditions

Temperature	23 °C ± 5 °C
Humidity	35 – 95%
Detail test cycle:	1 cycle of 8 hours

The test has to be carried out on a new or undamaged lock.

Before the test, the function of the lock must be checked (lock and unlock the unit, withdraw and insert the key after locking).

The dust test preparation will be performed using the dust test cycle of the standard IEC 60529 IP5 (class 2) dust cycle (8 hours) with Arizona quartz dust (A2 fine according to ISO 12103) or an equivalent dust medium.

The lock is placed in a dust chamber for 8 hour (the number of hours mentioned in the directive).

The standard acceptance conditions of the IEC 60529 IP5 directive are not applicable for the tested lock.

2.2.2.2 Test procedure

The lock is placed in a dust chamber (installed in the fixture, see images below).

The position of the lock during the dust test cycle will be simulating the way of "normal use".

If unknown, the worst situation will be taken (e.g. hanging upright or upside down). This is to be determined by the testing authority (test house).

After the dust test cycle is performed (the number of hours is mentioned in the directive) the lock will be gently brushed with a soft brush to remove any excess dust before the final inspection.

After the dust test cycle the lock must not have lost its functions (capable of functioning normally).

Remark: the lock must be able to be opened with a reasonable maximum torque on the key (e.g. 2,5 Nm max). Therefore it is permitted to make the product functional for 2 minutes with manual force and using only the correct key. Ingress of dust is not entirely prevented, but it must not enter in sufficient quantity to interfere with the satisfactory operation of the equipment.

Based on locking and unlocking the lock, as well as inspection of the lock, it is decided whether the requirements are fulfilled or not.

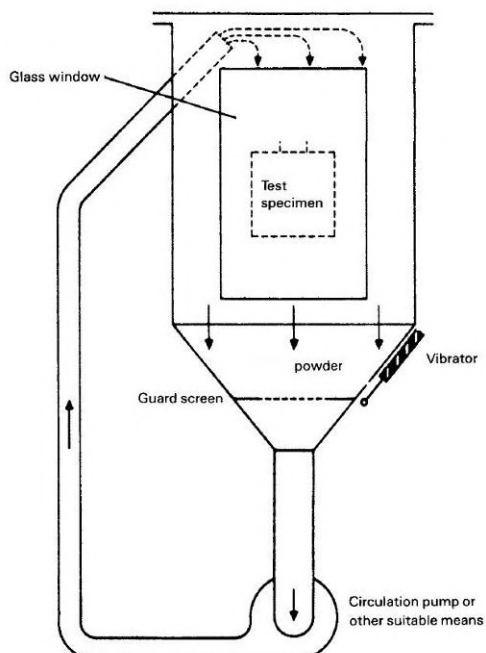

2.2.3 Freeze resistance / Cold test (mechanical locks)

The lock must withstand exposure to a complete freeze cycle (30 hr in total, see details mentioned below) such that it will still function properly (without loss of function) directly after the freeze test.

2.2.3.1 Test conditions

Temperature	23 °C ± 5 °C
Humidity	35 – 95%
Detail test cycle:	1 cycle of 30 hours
Test conditions:	a. Preparation (a lock together with a 1 L. hot water container in a dense packing), b. Stabilize for 24 hours, c. 6 hours freezer -20 °C, d. Function test with a key within 60 seconds after removed from the freezer.

The test has to be carried out on a new lock.

Before the test, the function of the lock must be checked (lock and unlock the unit, withdraw and insert the key after locking). The freeze test will be performed following the test procedure instructions below.

The keys shall be kept at room temperature.

2.2.3.2 Test procedure

The lock shall be placed in a voluminous dense packing with a holding capacity (volume) of no more* than 100 litre such as a roomy plastic box (thin wall home use storage box) or a large plastic bag that can be closed and which could be place easily in a freezing cabinet (or climate chamber).

The lock during the freeze test will be positioned on a partly raise wire mesh plateau and simulating the way of "normal use". If unknown, the worst situation will be taken (e.g. upright, lying flat, other).

This is to be determined by the testing authority (test house).

To achieve the lock is subjected to an as high as possible (<100%) relative humidity there shall be added an insulated warm water container (a large free opening on the top, for fogging-vapour formation purpose) with 1 litre (± 10%) of boiled water (the water should have boiled max, 3 minutes before) and the box or bag is closed. The dense packing with the lock and water container is held for 24 hours (± 2hr) in a room (normal environment) at a temperature of +23 °C (± 5 °C) considering that after that the lock, the vapours and water container have also reached this temperature and condensation is evident.

*) Remark: if a very large dimension lock is tested which cannot fit in a 100 litre bag (or box) then a larger volume is possible under the condition that additionally one (1) litre (hot) water is used for every 100 litre extra volume.

Immediately afterwards, without wiping off or shaking off the drops of water, the still closed dense packing is placed in a climate chamber (already) cooled down to -20 °C (± 1 °C) for 6 hours (± 1hr) (see images below). Remark: The lock must be at this temperature long enough that one can consider that the whole lock has been cooled to this temperature.

After the freeze test cycle is performed the lock shall be taken out of the climate chamber (and packing) and tested immediately according to unlocking function (test the lock locking mechanism with the key).

After the test the lock must not have lost its functions (capable of functioning normally).

Therefore it is permitted to make the product functional for a certain time (e.g. 1 or 2 minutes) with manual force and using only the correct key.

Remark: the lock must be able to be opened with a practical maximum torque on the key (e.g. 2,5 Nm max).

Based on locking and unlocking the lock, as well as inspection of the lock, it is decided whether the requirements are fulfilled or not.

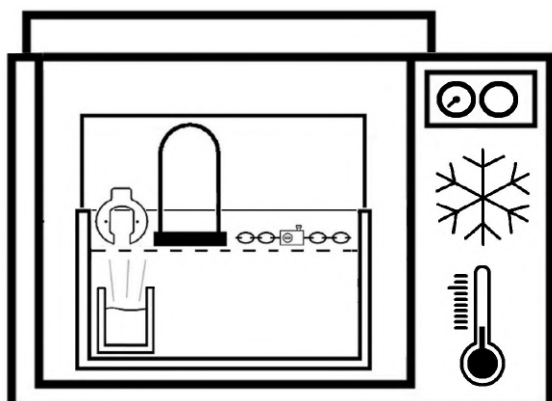

2.2.4 Freeze resistance / Cold test (electronically operated locks)

The E-lock (e.g.: a mechatronic lock) must withstand exposure to a freeze cycle (≥ 4 hour) such that it will still function properly (without loss of function) directly after the freeze test..

2.2.4.1 Test conditions

Temperature	23 °C \pm 5 °C
Humidity	35 – 95%
Detail test cycle:	1 cycle of 4 hours
Test conditions:	a. 4 hours freezer -10 °C, b. Function test started within 60 seconds after removed from the freezer.

The test has to be carried out on a new lock with new and/or fully charged batteries.
Before each individual test, the function of the E-lock must be checked (lock and unlock the unit).
The freeze test will be performed following the test procedure instructions below.
The E-lock is placed in a freeze chamber for 4 hours.
The physical electronic keys shall kept at room temperature.

2.2.4.2 Test procedure

The lock shall be placed in a freezing cabinet (or climate chamber) already cooled down to -10 °C (± 1 °C) for a minimum of 4 hours (see images below).

The position of the lock during the freeze test will be simulating the way of “normal use”. If unknown, the worst situation will be taken (e.g. upright, lying flat, other).

This is to be determined by the testing authority (test house).

Remark: The E-lock must be at this temperature long enough that one can consider that the whole lock has been cooled to this temperature.

After the freeze test cycle is performed the E-lock shall be taken out of the climate chamber and tested immediately according to locking and unlocking function.

After the test the lock must not have lost its functions (capable of functioning normally).

Therefore it is permitted to make the product functional for 2 minutes.

Based on locking and unlocking the lock it is decided whether the requirements are fulfilled or not.

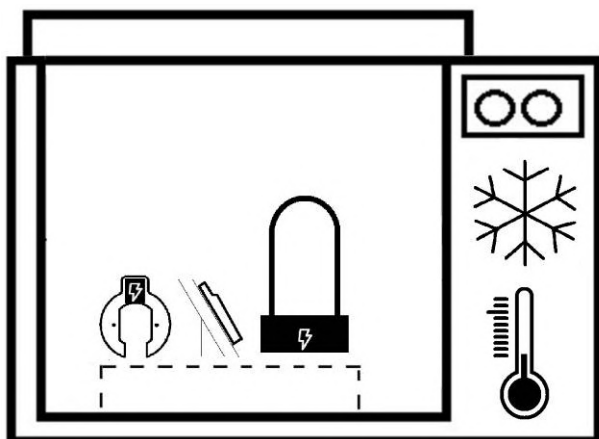

2.3 Mechanical strength tests (machine tests)

2.3.1 Torsional (torque) strength

The non-permanently fitted lock (such as a U-shackle lock, a folding and/or pivoting lock) should be designed so that a torque load or rotation can be achieved without the lock being forced (not ruptured and open). The lock must be able to satisfy the requirements mentioned in the relevant directive.

The lock must be able to satisfy the requirements mentioned in the relevant directive.

2.3.1.1 Test conditions

Temperature 23 °C ± 5 °C
Humidity 35 – 95%

The torsional strength test only has to be carried out if a leverage attack on that lock can occur in practice. The test has to be carried out on a new or undamaged lock.

Before the test the lock must be locked and checked after withdrawing the key.

The torque strength test will be performed following the U-shackle lock test method (not the value) of the European Standard EN 15496, paragraph 6.5.4.2.

The torque is applied as evenly as possible (e.g. a bicycle lock could be tested at a rate of approx. 200 Nm/min).

2.3.1.2 Test procedure

The lock is installed in a torsion strength test machine (mounted in the test-rig, see drawing/images below).

The position of the U-shackle lock (or folding/pivoting lock) during the torsion strength test will be such that the lock body is placed on top (hanging over the upper rotating bar of the fixture).

The diameter of both bars will be 30 mm ±5 mm. The lower (length adjustable) stationary bar shall be positioned according to the distance calculated in the European Standard EN 15496, paragraph 6.5.4.2. figure 4 (torsional strength test on U-shackle locks).

If due to the shape of the U-part or the type of lock (folding/pivoting lock) it is not possible to calculate the distance of both bars of the torsion strength test machine an equivalent distance or set-up will be taken (with sufficient play to compensate the length reduction of the lock when torqued (twisted)). This is to be determined by the testing authority (test house).

Type 1 procedure:

Gradually apply torque to the lock until the lock or shackle breaks or until the (minimal) required torque is achieved and retained for 1 minute before being relieved, whichever occurs first.

Type 2 procedure:

Gradually apply torque to the lock until the lock or shackle breaks, until the test is stopped because the minimum required value is exceeded to a large extent (no breakage occurred) or until the test is stopped because it is not possible to turn free anymore (e.g. totally twisted without breakage of parts or partially twisted until the two parts touch each other without breakage of parts), whichever occurs first.

If a lock breaks (rupture occurred) with such a small gap between the broken (shackle) parts that a passage of a shaft diameter of 30 mm is not possible (protective sleeve cut or removed) the lock is considered to have stayed "closed" after the torque test (impossible to remove the twisted lock, it still kept its anti-theft characteristics).

Based on the values measured, behaviour during the test, as well as inspection of the lock, it is decided whether the requirements are fulfilled or not.

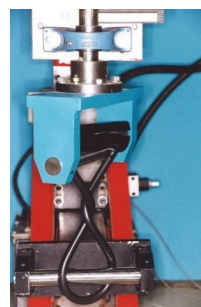
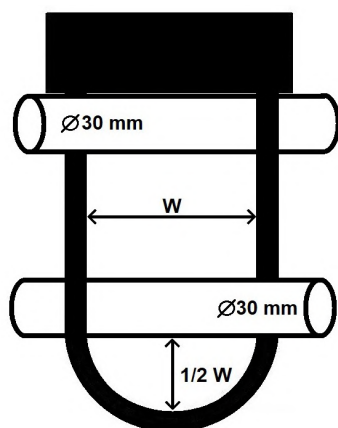

2.3.2 Tensile strength

The lock should be designed so that a certain tensile load can be achieved without the lock being forced (not ruptured and open).

The lock must be able to satisfy the (applicable) requirements mentioned in the relevant directive.

2.3.2.1 Tensile strength test 1a (in direction of opening - U-shackle lock)

The non-permanently fitted U-shackle lock shall withstand a specific load, applied at the angle similar to the direction of opening. The minimum load required is mentioned in the relevant directive.

This test 1 series test method (in direction of opening) is the standard performed tensile strength test method.

2.3.2.1.1 Test conditions

Temperature	23 °C ± 5 °C
Humidity	35 – 95%

The tensile strength test only has to be carried out if the loading on that lock can occur in practice.

The test has to be carried out on a new or undamaged lock.

Before the test the lock must be locked and checked after withdrawing the key.

The tensile strength test will be performed partially similar to the U-shackle lock test method (not the value) of the European Standard EN 15496, paragraph 6.5.3.2.1

The force is applied as evenly as possible (e.g. a bicycle lock could be tested at a rate of approx. 10 kN/min).

2.3.2.1.2 Test procedure

The lock is installed in a tensile strength test machine (mounted in the test-rig, see images below).

The position of the U-shackle lock during the tensile strength test will be such that the lock body is held on one side of the tensile device and the U-shackle part is held at the opposite side.

The tensile load shall be spread as evenly as possible over the width of the lock body (at least 80% (+10%, -0%) shall be covered) and over the curved part of the U-shackle (the diameter of the upper round* tensile device shall be at least 80% (+10%, -0%) of the U-part inner width).

*) The upper device does not generally need to be round. If the design is such that it does not permit a (round) tensile device of these dimensions, then the best fitting and biggest device possible must be selected.

In that case an equivalent distance or set-up will be taken. This is to be determined by the testing authority.

Type 1 procedure:

Gradually apply a tensile load to the lock until the lock or shackle breaks or until the (minimal) required force is achieved and retained for 1 minute before being relieved, whichever occurs first.

Type 2 procedure:

Gradually apply a tensile load to the lock until the lock or shackle breaks or until the test is stopped because the minimum required value is exceeded to a large extent (no breakage occurred), whichever occurs first.

Based on the values measured, as well as inspection of the lock, it is decided whether the requirements are fulfilled or not.

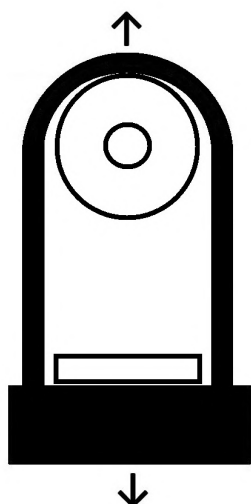

2.3.2.2 Tensile strength test 1b (Fully flexible (e.g. cable) locks).

The flexible (cable) lock shall withstand a specific load, applied at the angle similar to the direction of stretch out a closed lock (load mostly in direction of opening). The minimum load required (tested as a loop) is mentioned in the relevant directive.

This test 1 test method (in direction of stretch out) is the standard tensile strength test method (for cables).

2.3.2.2.1 Test conditions

Temperature	23 °C ± 5 °C
Humidity	35 – 95%

The tensile strength test only has to be carried out if the loading on that lock can occur in practice.

The test has to be carried out on a new or undamaged lock.

Before the test the lock must be locked and checked after withdrawing the key.

The tensile strength test on a flexible (cable) lock will be performed partially similar to the cable lock test method (not the value) of the European Standard EN 15496, paragraph 6.5.3.3 (“Other locks”)

The force is applied as evenly as possible (e.g. a bicycle lock could be tested at a rate of approx. 10 kN/min).

2.3.2.2.2 Test procedure

The lock is installed in a tensile strength test machine (mounted in the test-rig, see images below).

The position of the flexible (cable) lock during the tensile strength test will be such that lock body is positioned halfway between the two (2) round tensile strength test devices for supporting the flexible (cable) part.

The tensile load shall be spread as evenly as possible over the surface of the flexible (cable) lock.

The diameter B of the round tensile device shall be at least 80mm.

This is for the determination of the testing authority (test house).

Type 1 procedure:

Gradually apply a tensile load to the lock until the lock or shackle breaks or until the (minimal) required force is achieved and retained for 1 minute before being relieved, whichever occurs first.

Type 2 procedure:

Gradually apply a tensile load to the lock until the lock or shackle breaks or until the test is stopped because the minimum required value is exceeded to a large extent (no breakage occurred), whichever occurs first.

Based on the values measured, as well as inspection of the lock, it is decided whether the requirements are fulfilled or not.

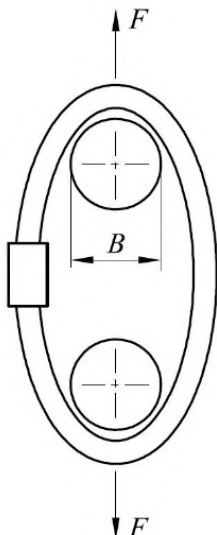

2.3.2.3 Tensile strength test 1c (Hard link (e.g. chain and folding) locks).

The hard link flexible lock (locks with limited flexibility connections) shall withstand a specific load, applied at the angle similar to the direction of stretch out a closed lock as described in tensile strength test 1b. The minimum load required (tested as one (1) long string) is mentioned in the relevant directive. This required value (normally) is 50% of the minimum load if the flexible lock tested is as a close loop. This one string test method (in direction of stretch out) is the standard test method for folding locks.

2.3.2.3.1 Test conditions

Temperature	23 °C ± 5 °C	Humidity	35 – 95%
-------------	--------------	----------	----------

The tensile strength test only has to be carried out if the loading on that lock can occur in practice. The preparation of the tests sample (needed for the test) has to be carried out on a new or undamaged lock. Before the test the lock-head or padlock must be locked and checked after withdrawing the key. For “low strength” (bicycle) chain locks the test method for fully flexible locks (see tensile strength test method 1b) can be used as well. This is to be determined by the testing authority (test house). Remark: Above mentioned low strength products are chains or folding locks with multiple small (cross section dimensions) and very short links (length dimensions) that could easily follow the radius of a device not causing extra stress in the supported links (hereby ensured that the mounting device does not affect the test result). For “high strength” hard link flexible locks (bike, scooter and motorbike) the 1 string test method shall be used. The tensile strength test as one string on a flexible lock (with hard connection links or connection bars) will be performed on a prepared lock sample (that is cut or ground through opposite to the closing lock body side). The stretched lock part shall be as long as possible and shall include at least 2 chain links on each side of the lock body / locking element (in case of a chain lock) or at least 2 connection bars on each side of the lock body / locking element (in case of a folding lock). If this is not possible then an extra test shall be performed on a separate piece of chain links only or on a separate piece with a number of (folding lock) connection bars. The force is applied as evenly as possible (e.g. a bicycle lock could be tested at a rate of approx. 10 kN/min).

2.3.2.3.2 Test procedure

The stretched lock part for the one string tensile strength test is installed in a tensile strength test machine (mounted in a test-rig, see drawings and images below). The position of the locking (closing) part during the tensile strength test will be such that the lock body is positioned halfway between the two (2) tensile strength test devices. The tensile load shall be spread as evenly as possible to the two chain end links or the last connection links. This is to be determined by the testing authority (test house). When chains and other hard link flexible locks are strength tested as a (long) string, the tensile strength test values (applies if tested as a loop) in the table of appendix 2 of MBT-04 2019 may be halved (50%).

Type 1 procedure:

Gradually apply a tensile load to the lock until the lock or shackle breaks or until the (minimal) required force is achieved and retained for 1 minute before being relieved, whichever occurs first.

Type 2 procedure:

Gradually apply a tensile load to the lock until the lock or shackle breaks or until the test is stopped because the minimum required value is exceeded to a large extent (no breakage occurred), whichever occurs first.

Based on the values measured, as well as inspection of the lock, it is decided whether the requirements are fulfilled or not.

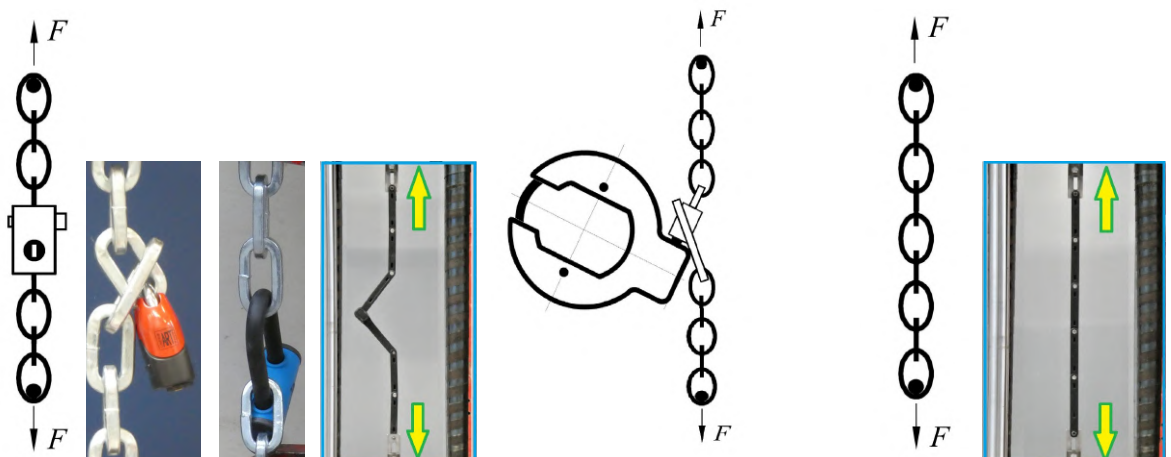

2.3.2.4 Tensile strength test 2 (perpendicular to the direction of opening - U-shackle lock)

The non-permanently fitted U-shackle lock shall withstand a specific side load, applied at the angle perpendicular to the direction of opening. This test 2 test method is not always required. If required than the minimum load required is mentioned in the relevant directive.

2.3.2.4.1 Test conditions

Temperature	23 °C ± 5 °C
Humidity	35 – 95%

The tensile strength test only has to be carried out if the loading on that lock can occur in practice.

The test has to be carried out on a new or undamaged lock.

Before the test the lock must be locked and checked after withdrawing the key.

The tensile strength test will be performed partially similar to the U-shackle lock test method (not the value) of the European Standard EN 15496, paragraph 6.5.3.2.2 with the exception of the position of the pulling devices (the devices halfway up the lock u-shackle (L/2) instead of close to the lock housing).

The force is applied as evenly as possible (e.g. a bicycle lock could be tested at a rate of approx. 10 kN/min).

2.3.2.4.2 Test procedure

The lock is installed in a tensile strength test machine (mounted in the test-rig, see images below).

The position of the U-shackle lock during this tensile strength test will be such that both the tensile devices are positioned opposite to each other inside and halfway to the length of the U-shackle part (L/2).

The diameter* A of the tensile devices will be at least twice the cross section diameter of the U-part ($\geq 2d \pm d$).

*) The tensile devices do not need to be round. If the design is such that it does not permit a (round) tensile device of these dimensions, then the best fitting and biggest device possible must be selected.

In that case an equivalent set-up will be taken.

This is to be determined by the testing authority (test house).

Type 1 procedure:

Gradually apply a tensile load to the lock until the lock or shackle breaks or until the (minimal) required force is achieved and retained for 1 minute before being relieved, whichever occurs first.

Type 2 procedure:

Gradually apply a tensile load to the lock until the lock or shackle breaks or until the test is stopped because the minimum required value is exceeded to a large extent (no breakage occurred), whichever occurs first.

Based on the values measured, as well as inspection of the lock, it is decided whether the requirements are fulfilled or not.

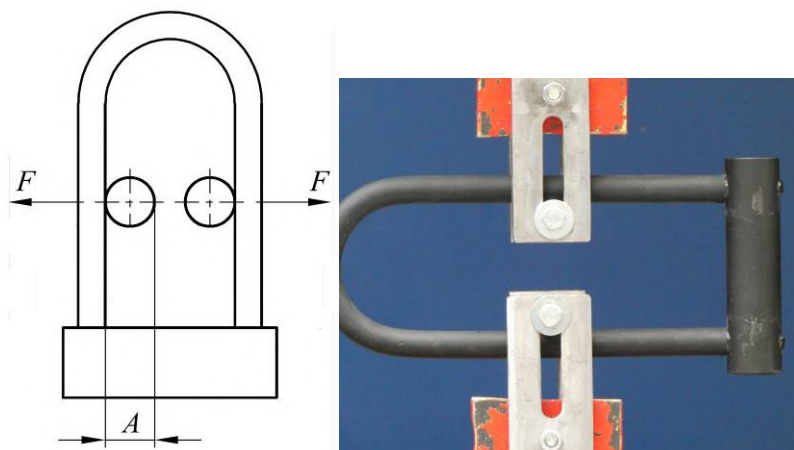

2.3.2.5 Tensile strength test 3 (anchor systems e.g. Wall- and Floor-anchors)

The permanently fitted anchor system (wall- and/or floor-anchor) shall withstand a specific tensile load, applied at the angle perpendicular to the mounting surface (such as brickwork or concrete). The minimum load required is mentioned in the relevant directive.

2.3.2.5.1 Test conditions

Temperature	23 °C ± 5 °C
Humidity	35 – 95%

The tensile strength test only has to be carried out if the loading on that wall- and floor-anchor can occur in practice.

The test has to be carried out on a new or undamaged wall- and/or floor-anchor.

In case of an anchor system with a lock mechanism the locking shall be checked before the test after withdrawing the key.

The force is applied as evenly as possible (e.g. a bicycle wall- and floor-anchor could be tested at a rate of approx. 10 kN/min).

2.3.2.5.2 Test procedure

For the tensile strength test a wall- and/or floor-anchor will be installed in a thick concrete floor (or a e.g. 2 x 2 metres high quality concrete plate simulating a concrete floor).

The anchor system test sample is fitted according to the supplied installation instructions* and using the supplied installation hardware (e.g. plugs) (mounted on a floor, see images below).

The position of the wall- and/or floor-anchor during the tensile strength test will be such that the eye (or other) intended to secure the vehicle is perpendicular to the mounting surface (floor) and pointing towards the tensile device.

The tensile load is applied to the anchor using a tensile device simulating an inserted chain or U-lock.

The diameter* of the tensile device shall be at least twice the cross section diameter of the eye ($\geq 2 d$).

Remark: If the installation instructions describe an assembly from which it is plausible that this will not be common practice then the testing authority is allowed to deviate from the instructions after informing the client.

*) The tensile device does not need to be round. If the design is such that it does not permit a (round) tensile device of these dimensions, then the best fitting must be selected. In that case an equivalent set-up will be taken.

This is to be determined by the testing authority (test house).

Type 1 procedure:

Gradually apply a tensile load to the product until the wall- and/or floor-anchor eye breaks, separation occurred (anchor parts or from the concrete) or until the (minimal) required force is achieved and retained for 1 minute before being relieved, whichever occurs first.

Type 2 procedure:

Gradually apply a tensile load to the product until the wall- and/or floor-anchor eye breaks, separation occurred (anchor parts or from the concrete) or until the test is stopped because the minimum required value is exceeded to a large extent (no breakage occurred), whichever occurs first.

Based on the values measured, as well as inspection of the wall- and/or floor-anchor, it is decided whether the requirements are fulfilled or not.

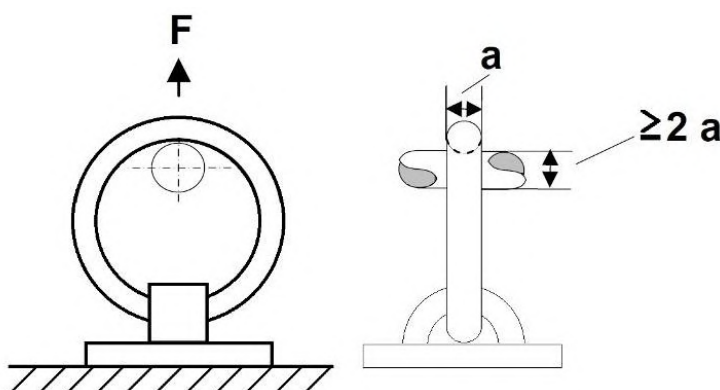

2.3.2.6 Tensile strength test 4a (simulated cylinder pull test (pushing from the opposite side))

The lock shall withstand a specific load, applied at the angle similar to the direction of extraction of the cylinder (and key).

The minimum load required is mentioned in the relevant directive.

This test 1 series test method (simulated pull test) is the standard lock cylinder attachment strength test method as the keyway and the hole that provide anchorage for the threads of a pulling screw (or tool) do not affect the test result.

If the construction of the retaining device of the key mechanism or the lock's blocking mechanism (e.g. clamp style brake disc locks with a double locking pin) is weakened by a hole in the lock, then an actual pull test (2.3.2.7, Tensile / pulling strength test 2 with a pulling screw) should be conducted instead.

2.3.2.6.1 Test conditions

Temperature	23 °C ± 5 °C
Humidity	35 – 95%

The simulated pull test only has to be carried out if extraction of the plug/ lock cylinder is physically possible and can occur in practice.

The preparation of the tests sample (needed for the test) has to be carried out on a new or undamaged lock. Before the test the lock body holding the attachment of the cylinder shall be modified to provide access to the back of the cylinder plug. This can be done e.g. by making an auxiliary hole from the opposite side of the keyway. The auxiliary hole or other modification must not be positioned such that any part of cylinder attachment is affected.

The (simulated) tensile strength test will be performed partially similar to the padlock test method (not the value) of the European Standard EN 12320:2001, paragraph 5.4.3

The force is applied as evenly as possible (e.g. a bicycle lock could be tested at a rate of approx. 7 kN/min.).

2.3.2.6.2 Test procedure

The lock body is placed under the strength test machine on an undeformable support (e.g. a steel base with a hole or on rigid steel blocks) with enough space under the object to make extraction of the plug/cylinder possible without interference (not to provide support for the lock at the attachment point of the cylinder) (see images below).

The load shall be spread as evenly as possible over the back of the cylinder plug (e.g.: a large diameter* loading device without interference with the lock body). If the design is such that it does not permit a round loading device, then the best fitting and biggest device possible must be selected.

In that case an equivalent distance or set-up will be taken.

This is to be determined by the testing authority (test house).

Type 1 procedure:

Gradually apply a load to the lock (cylinder) until the attachment points of the cylinder breaks or until the (minimal) required force is achieved and retained for 1 minute before being relieved, whichever occurs first.

Type 2 procedure:

Gradually apply a load to the lock until the attachment points of the cylinder breaks or until the test is stopped because the minimum required value is exceeded to a large extent (no breakage occurred), whichever occurs first.

Based on the values measured, as well as inspection of the lock, it is decided whether the requirements are fulfilled or not.

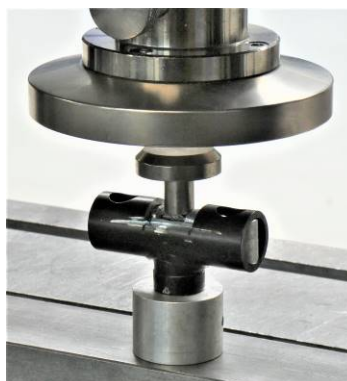
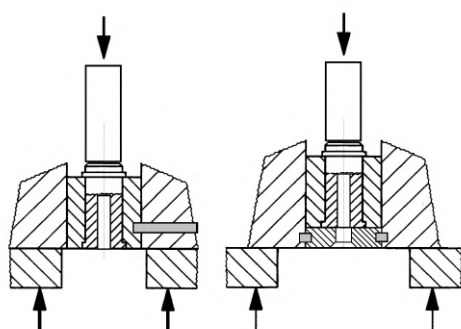

2.3.2.7 Tensile strength test 4b (actual plug/cylinder extraction test with a pulling screw)

The lock shall withstand a specific load, applied at the angle similar to the direction of extraction of the cylinder (and key).

The minimum load required is mentioned in the relevant directive.

This test 2 series test method (actual pull test) is the strength test method to be used when the construction of the retaining device of the key mechanism (fixation) or the lock's blocking mechanism (e.g. with clamp style brake disc locks with a double locking central pin) is weakened by a hole in the lock.

2.3.2.7.1 Test conditions

Temperature	23 °C ± 5 °C
Humidity	35 – 95%

The actual pull test only has to be carried out if extraction of the plug/ lock cylinder is physically possible and can occur in practice.

The preparation of the tests sample (needed for the test) has to be carried out on a new or undamaged lock. Before the test and final preparation the lock must be locked on a fixture and checked after withdrawing the key. A special purpose high quality self cutting pulling screw (e.g. in accordance to EN ISO 10666, EN ISO 15480, EN ISO 15481, EN ISO 15482 and EN ISO 15483) shall be screwed into the plug/cylinder together with a metal fixture holding the traction screw or with a washer or traction tool which is designed in such a way that it can be mounted (used) without unscrewing the screw.

It shall be tried attaching the best fitting or biggest possible self cutting pulling screw in the keyway.

More than one pulling test is allowed on the same cylinder with different screw diameters.

The tensile strength test will be performed partially similar to the test methods (not the values) of the European Standard(s) EN 15496, paragraph 6.5.8.3 (for bicycle locks), EN 12320:2012, paragraph 5.5.3. (for padlocks) or EN 1303:2015, paragraph 6.9.4 (Building hardware - Cylinders for locks).

The force is applied as evenly as possible (progressively without shocks) to the traction tool of the screw (e.g. a bicycle lock could be tested at a rate of approx. 7 kN/min.).

The test is deemed to have been passed as well if the screw cannot be inserted.

2.3.2.7.2 Test procedure

The lock is placed in the strength test machine mounted under or on an unreformable support with enough space to make extraction of the plug/cylinder possible without interference (not to provide support for the lock at the attachment point of the cylinder) (see images below).

The load of the unmovable support on the lock shall be spread as evenly as possible over the width of the lock body. This is to be determined by the testing authority (test house).

Type 1 procedure:

Gradually apply a load to the lock (cylinder) through the pulling screw until the attachment points of the cylinder breaks, until the screw breaks, until the screw is completely withdrawn from the plug or until the (minimal) required force is achieved and retained for 1 minute before being relieved, whichever occurs first.

Type 2 procedure:

Gradually apply a load to the lock until the attachment points of the cylinder breaks, until the screw breaks, until the screw is completely withdrawn from the plug or until the test is stopped because the minimum required value is exceeded to a large extent (no breakage occurred), whichever occurs first.

Based on the values measured, as well as inspection of the lock, it is decided whether the requirements are fulfilled or not.

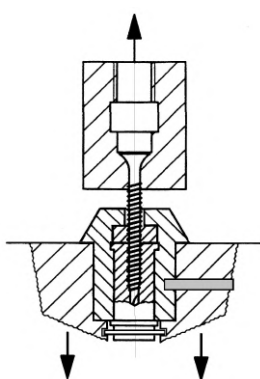

2.3.2.8 Tensile strength test 5 (pull out the additional mean – Plug-in mechanism)

The (integrated) additional means (plug-in) locking mechanism of a frame lock and the fixation of the flexible part of an additional means to the plug shall withstand a specific load, applied at the angle similar to the direction of extraction of the plug-in.

The minimum load required is mentioned in the relevant directive.

2.3.2.8.1 Test conditions

Temperature	23 °C ± 5 °C
Humidity	35 – 95%

The tensile strength test only has to be carried out if the loading on that lock can occur in practice.

The test has to be carried out on a new or undamaged lock.

Before the test both the lock and plug-in must be locked and checked after withdrawing the key.

The stretched lock part shall include several chain links (in case of a chain lock) or several connection bar pivots (in case of a folding lock).

The force is applied as evenly as possible (e.g. a bicycle lock could be tested at a rate of approx. 10 kN/min).

2.3.2.8.2 Test procedure

The lock is installed in a tensile strength test machine (mounted in the test-rig, see images below).

The position of the frame lock during the tensile strength test will be such that the lock body is held firmly in position during the tensile test (with the help of supports if needed).

The end of the additional means part (chain, cable, bars, others) shall be firmly attached to the tensile test machine. The diameter of the upper pin shall be at least 80mm for the cables and as best fitted as possible for chains or other links. This is for the determination of the testing authority (test house).

Type 1 procedure:

Gradually apply a tensile load to the additional means part until rupture of the plug-in or its locking mechanism, until the connection of the flexible part to the plug-in breaks or until the (minimal) required force is achieved and retained for 1 minute before being relieved, whichever occurs first.

Type 2 procedure:

Gradually apply a tensile load to the additional means part until rupture of the plug-in or its locking mechanism, until the connection of the flexible part to the plug-in breaks or until the test is stopped because the minimum required value is exceeded to a large extent (no breakage occurred), whichever occurs first.

Based on the values measured, as well as inspection of the lock, it is decided whether the requirement is fulfilled or not.

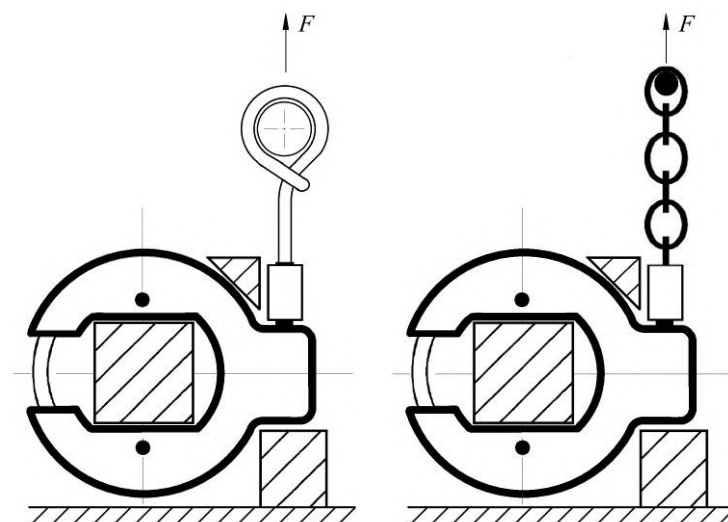

2.3.3 Cutting strength (resistance to shearing)

The lock should be designed so that a certain shearing load can be achieved without the lock being forced (not ruptured and open).

The lock must be able to satisfy the requirements mentioned in the relevant directive.

2.3.3.1 Test conditions

Temperature $23\text{ °C} \pm 5\text{ °C}$

Humidity 35 – 95%

The cutting strength (resistance to shearing) test has to be carried out if a bolt cropper attack on that lock can occur in practice during theft of an object (the accessibility of the product when fitted) or if performing the test is actually mentioned in the relevant directive.

For this an accessibility check* can be performed using a tool (e.g. bolt cropper) as prescribed in the directive.

*) If the bolt-cropper beaks can be positioned on the object the resistance to shearing test shall be performed.

The test has to be carried out on a new or undamaged lock or lock part (e.g. an U-shackle or chain-link).

The resistance to shearing strength will be performed partially similar to the “cutting resistance - test method” (not the value) of the European Standard EN 15496 (or EN 12320) using a set of (guided) shearing pieces (mandrels) and a rigid fixture to “simulate” the use (and the jaws) of a bolt cropper. The two shearing pieces shall be made of a high quality steel with sufficient yield strength (high forces can be applied without producing permanent deformation) and a hardness of $61\text{ HRC} \pm 3\text{ HRC}$. Cutting edge 60° with a radius (R) = 1,5 mm. The force is applied as evenly as possible (e.g. a bicycle lock could be test at a rate of approx. 10 kN/min).

2.3.3.2 Test procedure

The lock is installed in a cutting strength test machine (positioned in the test-rig, see images below).

The position of the lock part during the cutting strength test will be such that the object’s longitudinal direction (axis) at the shear point is perpendicular to the cutting edges of the 2 shearing beaks and perpendicular to the direction of movement of the (upper) shearing beak (reduce the cross section of the cut material to a minimum). This is to be determined by the testing authority (test house).

Type 1 procedure:

Gradually apply a cutting load to the lock (part) until the lock or lock part breaks or until the (minimal) required force is achieved and retained for 1 minute before being relieved, whichever occurs first.

Type 2 procedure:

Gradually apply a cutting load to the lock until the lock or lock part breaks, until (if a chain link breaks on 1 side only*) the maximum displacement (distance)* of the cutting beak(s) is archived, or until the test is stopped because the minimum required value is exceeded to a large extent (no breakage occurred), whichever occurs first.

*) Remark: sometimes when, from a fully cut chain link (after a cutting strength test with “closed” cutting beaks), the loop function is still intact (links cannot be detached) a certain percentage can be added to the (maximum) applied force as a bonus.

This is mentioned and explained in the relevant directive.

Based on the (maximum) values measured, as well as inspection of the lock (part), it is decided whether the requirements are fulfilled or not.

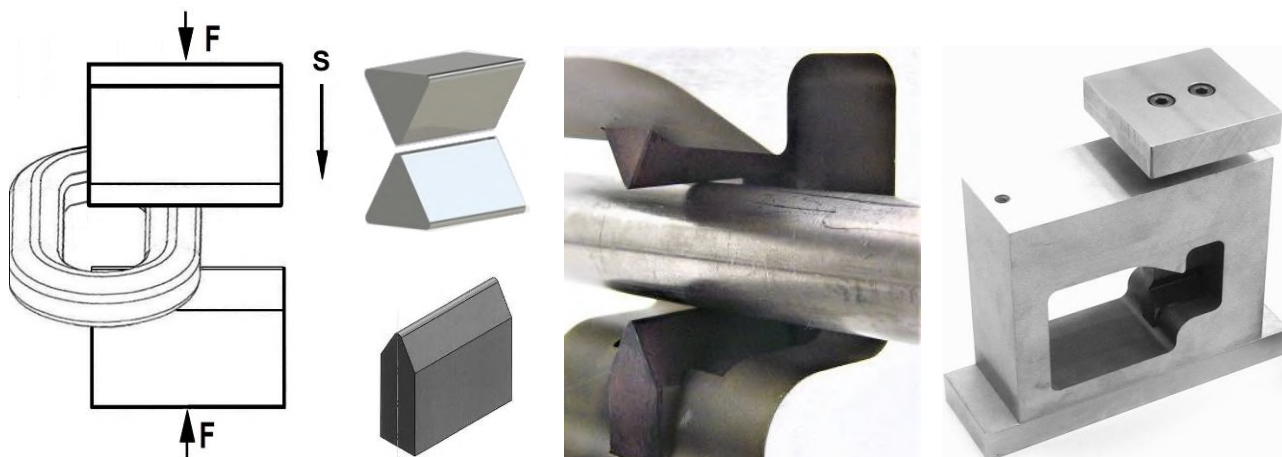

2.3.4 Powerkey torque strength (resistance to a Power-Key attack test cycle (2.0 version 2024)).

The lock should be designed so that it can withstand Power-key torque load without being forced (not open). The lock must be able to satisfy the requirements mentioned in the relevant directive.

2.3.4.1 Test conditions

Temperature 23 °C ± 5 °C Humidity 35 – 95%

The permanently fitted frame lock with a mechanical key system shall not open (withstand an attempt at unlocking) when a torque is applied in direction of opening through the keyhole with a special made tool. This high quality tool steel tool is called the “ART Power-Key” (similar Power-Key tools are often used by criminals for breaking locks with brute force through the keyhole) and a part of the tool simulate the key blade of a frame lock key. These “ART Power-Keys” shall have sufficient strength and shall be hand-in by the submitter. To guarantee uniform and as strong as possible test tools, all tools shall be made out of a (hard high quality spring steel) hex key L wrench (brand: PB Swiss Tools, type PB 211.12) with 1 or both ends of the tool’s straight hexagonal part modified to simulate the key blade of a frame lock key. The cross section dimensions of a modified end are identical to a key blade (based on manufacturer drawings). Only if necessary to make inserting the tool in the frame lock possible, a partially different shape can be chosen (e.g.: slant edges and/or a certain cutting depth for partially moving the blocking elements to insert the tool). The testing authority owns the hand-in ART Power-Key tools (for type-approval tests and random checks). The test has to be carried out on a new or undamaged frame lock.

2.3.4.2 Test procedure

The lock is installed in an ART Power-key torque strength test machine (e.g.: see images below). The position of the lock during the “ART Power-Key” strength test will be such that the key barrel’s longitudinal direction (turn-axis) is and stays (as much as possible!) in line with the centreline of the “ART Power-Key”. This is to be determined by the testing authority (test house).

The rotational speed during applying the torque loads may vary, however, “it must be tried” to complete a complete “ART Power-Key” torque test cycle within one (1) minute. Cycles could last longer due to play, deformation or collapsing locking parts. When load is applied the aim is to have a (average) rotational speed of 20° per second (±10%). In case of key barrels with a lot of rotation (play) before the load could be applied a temporary (average) rotational speed of 90° per second (±10%) can be used for the first 80% of rotation (play). To determine (measure) the key barrels rotation a pre-test measurement can be done (a pre load of 1 Nm will be applied in both turning directions to measure the total rotation). It is allowed that the rotation of this 80% part vary between steps (dynamic during the test) if the angle is based on the rotation in the previous step(s). If the test machine set-up is ready, an ART Power-Key torque test cycle is started were 1 or more forward and backwards turning torque loads are applied. In the **1st cycle** a load is applied in opening direction of **+2 Nm** (±10%) and after that a load is applied in opposite direction of only the half of the previous torque (e.g. **-1 Nm**). If no tools breakage occurred, the lock did not unlocked or turned free after applying both torques the test continued with every following cycle a twice as high load applied in opening direction (**cycle-2: +4 Nm/-2 Nm, cycle-3: +8 Nm/-4 Nm, cycle-4: +16 Nm/-8 Nm, cycle-5: +32 Nm/-16 Nm and cycle-6: +64 Nm/-32 Nm**). After the last load step cycle 6 two (2) additional cycle steps (7 and 8) are performed to see if the lock opens. after that -32 Nm step.

Based on the behaviour during the test, as well as inspection of the lock (part) after the tests, it is decided whether the requirements are fulfilled or not.



Final proposal test cycle(s) Power key test 2.0 (after the ART TC meeting 29-08-2024)

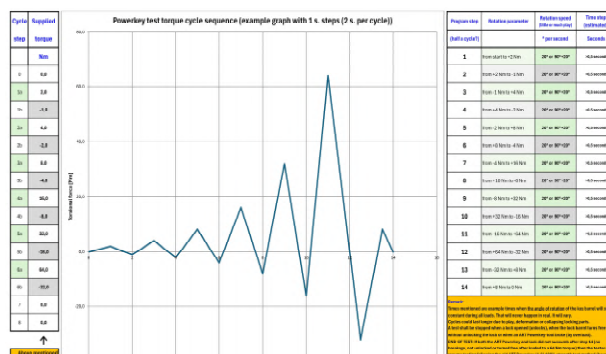

2.4 Mechanical strength tests (manual attack tests)

The resistance tests are being performed to determine the time of resistance against illegal opening of the lock. The number of tests, the minimum required time or used tools are mentioned in the relevant directives. The test program is prepared in order to perform as many tests as possible on as few locks as possible.

2.4.1 Attacking tests (resistance to lock picking)

2.4.1.1 Attacking test type 1 (manipulation/picking, non destructive unlocking test with hand tools)

The product must withstand a number of mechanical attempts at unlocking for a number of minutes using simple specific picking-tools. Normally this non-destructive test will be done through the key hole and actuating the blocking elements. As an alternative other openings could be used to unlock and open the lock. If applicable the minimum or maximum number of lock picking tests is mentioned in the relevant directive. This attacking test 1 test method (picking/manipulating) is only one (1) of all the (mech.) resistance tests. All requirements and limitations are mentioned in the relevant directives.

2.4.1.2 Test conditions

Temperature	23 °C ± 5 °C
Humidity	35 – 95%

The test has to be carried out on a new or undamaged lock (e.g. no use of the corrosion test sample). Before the test the lock must be locked and checked after withdrawing the key. Before all tests and after studying the drawings and an unassembled lock on loose parts (or an opened up lock) the laboratory makes a lock pick test program and makes a choice of tools (or combinations) from the list. The key of the test lock shall not be studied before and during the test. The keys are placed out of sight. The attempts at unlocking are executed by a person (Lock Expert) with good craftsmanship qualifications. The lock shall be fixed in a way that makes lock picking convenient for the tester (i.e. not necessarily mounted on a two-wheeler or in a vehicle (fragment)) and picked under “normal” conditions possible in practice. As alternative the manipulating/lock picking tests could be performed following the test method (not the value) of the European Standard EN 15496, paragraph 6.8 as a guide. In this case 10 different tests shall be performed on 10 (+2) different locks. The need to use this method is mentioned in the relevant directives. In some homologation directives a point system is used. For every attempt at unlocking the time is determined which is needed to open the lock. This time refers to certain points.

2.4.1.3 Test procedure

An accredited person (e.g. the Lock Expert) will try to open the lock with the help of the tools. An attempt at unlocking (the total, effective time) must not take more than the time specified in the relevant directive(s). It is preferred to test without interruptions, however, pausing the test is allowed, as well as the time, if it is necessary for the tester or lock expert to inspect the lock, provide advice to the tester or similar. If the test has been paused during an attack and the lock fails or is expected to fail with a new approach, the attack is preferred to be repeated on a new sample without interruptions for the results to be valid. This for the determination of the Lock Expert (or the testing authority / test manager). During each individual attempt at unlocking, the tester must not receive any assistance from other people present other than advice and instructions. An attempted attack is stopped if the lock can be opened, when the time has expired or due to a decision made by the tester or the Lock Expert.

Based on the values measured, as well as inspection of the lock, it is decided whether the requirements are fulfilled or not. If a lock fails an attempt at unlocking, meaning the lock opening, the test can be repeated on at least one other lock to determine the extent of the flaws of the lock.

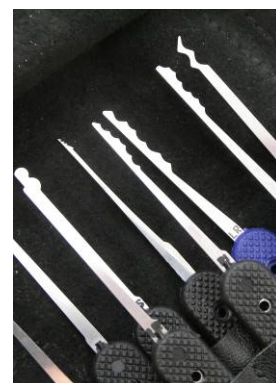
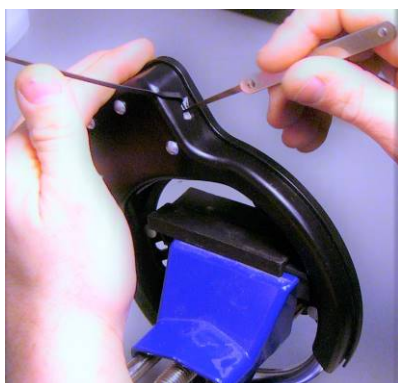

2.4.2 Attacking tests (resistance to brute attacks)

2.4.2.1 Attacking test type 2 (brute attack, destructive unlocking test with various hand tools)

The product must withstand a number of mechanical attempts at unlocking for a number of minutes using specific (hand) tools. Normally this destructive test will be done using brute force to unlock and open the lock. If applicable the minimum or maximum number of brute force tests is mentioned in the relevant directive. All requirements and limitations are mentioned in the relevant directives.

2.4.2.2 Test conditions

Temperature 23 °C ± 5 °C, Humidity 35 – 95%

The test has to be carried out on a new or undamaged lock.

The execution of multiple tests on the same sample is allowed if it does not influence the outcome of the test. After studying the drawings and an unassembled lock in loose parts (or an opened up lock), the tester and/or the Lock Expert makes a test program and makes a choice of tools (or combinations) from the list.

The lab owns manual and cordless tools, as described on the tool list in the relevant homologation directive. Tools must be in a generally good shape with sharp and intact jaws and blades.

For some tools there are limitations on the use of specific tools (e.g.: only be used for a limited time or the maximum number of tools). Each limitation for the use of the tools is clearly described in the relevant directive.

The system is tested under “normal” conditions depending on the product tested (e.g.: on a two-wheeler (against an independent test stand of the European Standard EN 15496, paragraph 6.7.2), on or in a vehicle fragment, on a floor or wall, simulated on an “unreformable” set-up or in a vice). A test stand, a fragment (fixated onto a solid stanchion) or similar set-up must be properly attached to the floor. The lock will be mounted on the test set-up as is supposed to be normal in practice preferred according to the manufacturers instruction. Should a manufacturer have special mounting requirements, it must be demonstrated (proofed) that in normal practice it is installed into the position in which the tests have actually taken place.

It is preferred to test without interruptions, however, pausing the test is allowed, as well as the time, if it is necessary for the tester or Lock Expert to inspect the lock, provide advice to the tester or similar.

If the test has been paused during an attack and the lock fails or is expected to fail with a new approach, the attack is preferred to be repeated on a new sample without interruptions for the results to be valid.

During each individual attempt at unlocking, the tester (operator) must not receive any assistance from other people present other than advice and instructions.

Tests may be stopped ahead of the time if the test institution and/or Lock Expert agrees that further attempts of unlocking will be fruitless (no sign of opening the lock with this M.O.) or after it is not possible anymore to continue testing (e.g.: blockade of access points due to breakage of tools).

In some directives a point system is used. For every attempt at unlocking (with 1 attack tool or combination of tools) the time is determined which is needed to open the lock. This time refers to certain points.

2.4.2.3 Test procedure

There will be tried to open the lock using a certain method (M.O.) with the help of the chosen tools.

An attempt at unlocking (effective time) must not take more than the time specified in the relevant directive(s). An attempted attack is stopped if the lock (system) can actually be opened/removed (and e.g. the vehicle can be moved), if the lock (system) loses its other anti-theft characteristics, when the time has expired or due to a decision made by the tester or the Lock Expert. If tested on an actual vehicle the main (frame) part shall remain secure after attacking tests are performed (shall function normally without unacceptable risk for the rider of the vehicle).

Based on the values measured, as well as inspection of the lock and frame, it is decided whether the requirements are fulfilled or not. If a lock fails an attempt at unlocking, meaning the lock opening, the test can be repeated on at least one other lock to determine the extent of the flaws of the lock.



2.5 Functional tests

2.5.1 Open field function test for E-locks (for mechatronic locks with a passive remote)

The smartphone/remote activated electronically operated locks (E-locks) must withstand unwanted opening while a nearby user (carrying a transmitting unlocking device) is unaware that the lock will be unlocked.

2.5.1.1 Test conditions

Temperature	25 °C ± 10 °C
Humidity	10 – 95%

The test has to be carried out on a new and fully charged lock and fully charged unlock device.

Before the test, the function of the E-lock must be checked (unlock and lock the unit).

The demand to perform this function test only applies to E-locks with an (“passively”) unlock device function (a remote, a smartphone, a transponder, etc.) that can open the lock automatically* if the user is nearby (without performing a physical action on the unlocking device).

*) Automatically means: e.g. opening the lock while moving or touching the lock (e.g. push a button on the lock) and:

- without performing an action in the app of a (Blue tooth operated?) Smartphone or,
- without pressing an unlock button on a remote or,
- when using (RFID) tags or equivalent (nearby).

In most cases a bike must be touched or moved to start the “lock to remote to lock” communication.

For automatically unlocking E-locks using such a transmitting unlocking device the maximum functional distance (e.g.: “communication”) between the transmitting unlocking device and the e-lock shall be limited.

The maximum distance shall be mentioned in the relevant directive.

E.g.: for ART the OEM settings in the most best condition (so called: “best” circumstances) for the distance to unlock an “e-lock” (without a physical action needed on the smartphone/remote) by signals transmitting through atmosphere shall be limited to maximum 5 meter. This will be checked by a function test in an open field.

2.5.1.2 Test procedure

The lock shall be fixed and closed according to the instructions (e.g.: placed on a bike or bicycle) or laying on the ground in an open field area. The position of the closed lock during the 5 meter function test will be simulating the way of “normal use”.

The transmitting unlocking device (smartphone/remote/transponder, etc.) will be laying on the ground or on a small platform (e.g. a table) during the test at the specified distance from the lock.

This is to be determined by the testing authority (test house).

Type 1 procedure:

Place the remote at a distance larger than the maximum allowed distance (e.g.: +2% ±1%).

In case of a remote with a “sleep function” move the remote (shaking, tilt or move) to wake-up the unlocking (unlocking) device (if applicable) shortly before the test. Immediately after that (if applicable) wake-up the lock (shaking, tilt or move) or touch the lock (e.g. press a button on the lock) to activate the unlocking function.

The lock shall not open.

Type 2 procedure:

Place the remote at a distance larger than the maximum allowed distance (e.g.: +20% ±1%).

In case of a remote with a “sleep function” move the remote (shaking, tilt or move) to wake-up the unlocking device (if applicable) shortly before the test. Immediately after that (if applicable) wake-up the lock (shaking, tilt or move) or touch the lock (e.g. press a button on the lock) to activate the unlocking function. If the lock did not open, move the E-lock closer to the remote (in steps of 50 cm) and repeat the tests until the lock opens.

From there move the E-lock away from the remote (in steps of 10 cm) until lock shall not open anymore.

The measured distance of the second last test shall comply to the requirements (ART: ≤ 5 meters).

Based on the behaviour of the E-lock, as well as inspection of the lock, it is decided whether the requirements are fulfilled or not. Independently of the result, any remarks from the test institution must be stated in the test report.

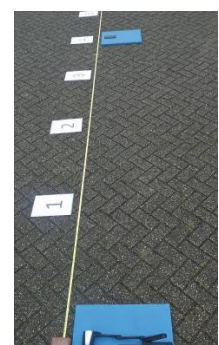
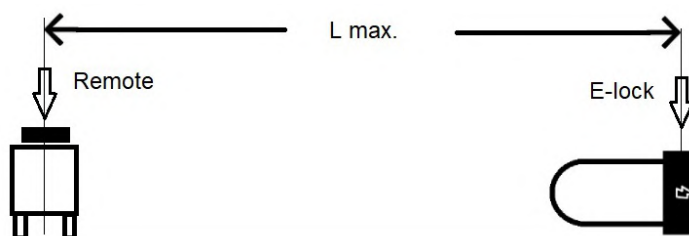

2.6 Various tests

In this guideline only the already used (Dutch) test methods are described.
There are many other tests possible for all kind of locks such as:

- Durability against water,
- Durability against wear,
- Key blade torque strength,
- Impacts on the lock body,
- Impacts on the shackle,
- Resistance to sawing (in a machine),
- Resistance to drilling (in a machine),
- Hardness tests,
- etc.

For above mentioned tests it is preferred that already proven test methods described in national and international standards will be used.

Examples of standards with proven test methods are:

- Varefakta - VF 5029 series (Bicycle Locks),
- Sold Secure – SS10* or SS30* Specification series (various mechanical security systems),
- SSF (the Swedish Theft Prevention Association) - SSF 011 series (Bicycle locks),
- TFF (the Swedish motor Insurers) – TFFN 701 / 702 series (locks for mopeds and motorcycles),
- SBSC (fire safety and security) – SSFN 026 series (locks for outboard motors),
- SBSC (fire safety and security) – SSF 1057 series (locks for trailer hitches),
- European standard - EN 15496 series (Cycles – Requirements and test methods for cycle locks),
- European standard - EN 12320 Building hardware (Padlocks and padlock fittings),
- Etc.

